



eLEMENT®

The ceiling fan - Reinvented!



The completely silent Element is purpose-built for sound-sensitive spaces such as schools, restaurants, retail stores and health clubs. A hybrid of proprietary technology and industrial-strength performance, Element is equipped with a gearless, direct drive motor and onboard controls that eliminate any noise or maintenance concerns. Fully customizable, Element can be built to complement your décor or stand out in jaw-dropping fashion. Its patented airfoil and winglet design, the cornerstone of all Big Ass Fans, generates high-efficiency air movement and energy savings. Element truly embodies the reinvention of the ceiling fan.

Features

- Silent operation even at full speed
- Industrial-strength air movement in a commercial design
- Available in diameters up to 20 feet (6.1 m)
- Fully customizable appearance packages
- Backed by a 10-year, non-prorated warranty



Ask how Big Ass Fans contributes to LEED® credits in:
Optimized Energy Performance; Enhanced Refrigerant Management;
Minimum Indoor Air Quality Performance; Increased Ventilation;
Thermal Comfort – Design; Innovation in Design.

 **BIG ASS FANS®**
WWW.BIGASSFANS.COM
An ISO 9001:2008 certified company

No Equal.

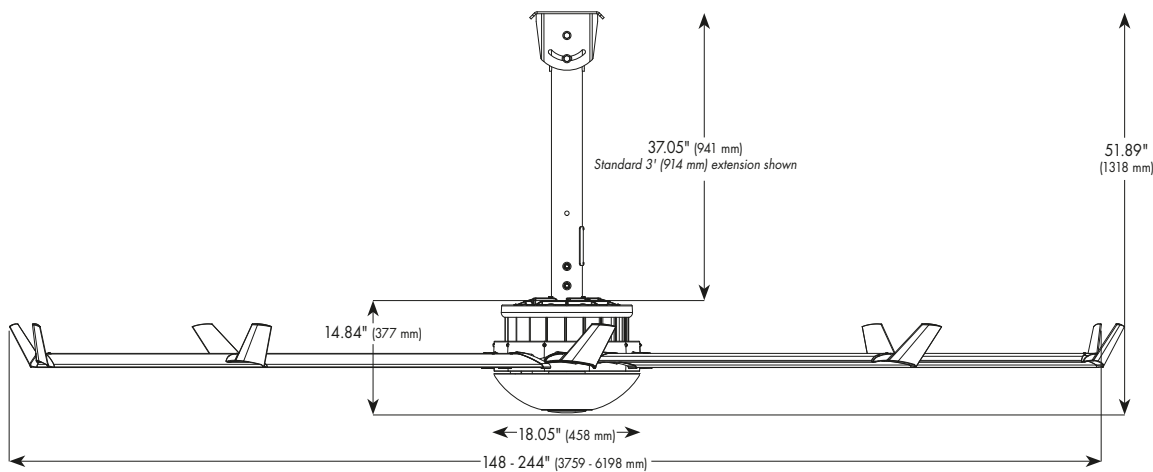

Technical Specifications	
Fan diameters	12 ft (3.7 m), 14 ft (4.3 m), 16 ft (4.9 m), 18 ft (5.5 m), 20 ft (6.1 m)
Fan weights	230 - 286 lbs (104 - 130 kg)
Max speeds	33 - 82 RPM (varies by fan size)
Airfoil number & type	10 patented TEC airfoils
Winglet	Element patented design, powder coated black
Standard finish	clear anodized aluminum and silver powder coat
Prime mover	gearless direct drive
Controller	Element LCD wall control
Fan speeds	fully adjustable to max RPM
Controller connection	Cat5, includes 3 ft (914 mm) test cable
Electrical supply	100 - 250 VAC, 50/60 Hz, 1 Φ , 10 A
Full load amps	6.4 - 4.5 A (110V) 3.2 - 2.3 A (220V)
Sound level (max RPM)	< 40 dBA
Extension tubes	2 - 10 ft (610 - 2048 mm) in 1 ft (305 mm) increments
Max mounting angle	45 degrees
Minimum airfoil clearances required	10 ft (3048 mm) above floor 2 ft (610 mm) on sides 2 ft (610 mm) below ceiling deck
Warranty	10 years with factory installation ¹

¹10 year parts, 1 year labor warranty; certain exclusions apply. See complete warranty for details.

Element Sizing Chart	Ceiling Height		
	15' (4.6 m)	25' (7.6 m)	35' (10.7 m)
Approximate Room Size			
40' x 40' (12.2 m x 12.2 m)	12 ft (3.7 m)	12 ft (3.7 m)	14 ft (4.3 m)
50' x 50' (15.2 m x 15.2 m)	12 ft (3.7 m)	14 ft (4.3 m)	16 ft (4.9 m)
60' x 60' (18.3 m x 18.3 m)	12 ft (3.7 m)	16 ft (4.9 m)	16 ft (4.9 m)

For optimum cooling in an active environment such as a gym or club, use the fan indicated in the sizing chart.

For more gentle and uniform air circulation in an environment such as an office, upsize the fan by 1 or 2 sizes from the sizing chart.

For larger areas, use multiple fans.

Covered by one or more of the following U.S. Patents: 6,244,821; 6,589,016; 6,817,835; 6,939,108; 7,252,478; 7,284,960; D587,799; D607,988 and other patents pending.

Controller

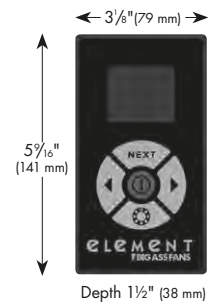

Optional Colors*

Ask about custom color options



*Standard model is anodized aluminum