

COLD FRONT 500

When you need maximum cooling coverage, trust the powerful performance of Cold Front 500. Durably engineered with a portable design, quiet and efficient motor, and advanced controls for convenient, hands-free use, Cold Front 500 delivers lasting comfort to large spaces both indoors and out. Backed by the industry's best warranty, it's the ultimate solution in evaporative cooling.



KEY FEATURES

- ▶ Quickly cool indoor and outdoor spaces by up to 33 °F (18 °C)
- ▶ Ideal for large warehouses, service bays, and stadiums
- ▶ 8-inch (20-centimeter) resin-treated cooling media
- ▶ 50-inch (127-centimeter) fan diameter
- ▶ 64-gallon (242-liter) reservoir lasts up to 10 hours without hose connection
- ▶ Onboard LED control panel with occupancy sensor

COVERAGE AREA

6,500 SQUARE FEET
(600 SQUARE METERS)

WARRANTY

5 YEARS

CONTROL

VARIABLE SPEED

VOLTAGE

110 V



BIG ASS FANS

**EXCEPTIONALLY
ENGINEERED**

STOP HEAT COLD

bigassfans.com/cold-front | Starting at **US\$5,100**

Call **877.244.3267** to transform your facility
with the cooling power of Cold Front.

COLD FRONT 500

DELIVER COOLER CONDITIONS AT A MOMENT'S NOTICE

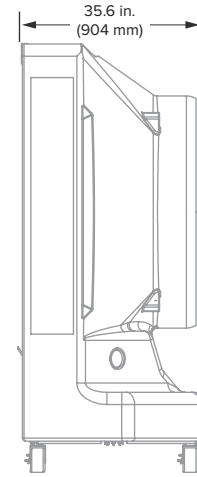
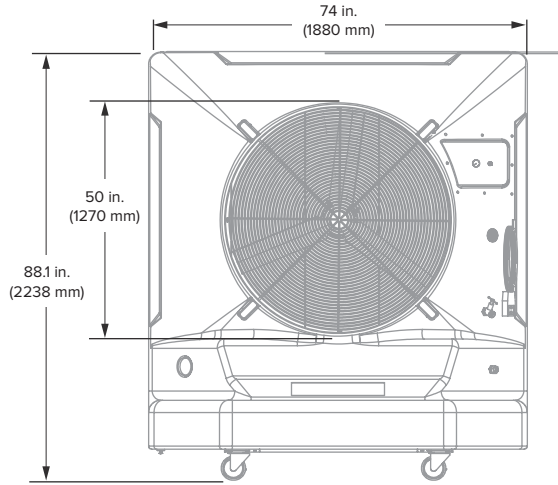

Technical Specifications

| Model | Ordering Information | Weight | Water Capacity | Inlet Water Supply Pressure | Input power and required breaker | Environment ¹ | Amperage ² | Airflow and Coverage | Sound Level ³ | Operating Temperature |
|----------------|----------------------|-------------------|----------------|-----------------------------|----------------------------------|---|-----------------------|----------------------------------|--------------------------|----------------------------|
| Cold Front 500 | F-EV1-5001 | 370 lb (167.8 kg) | 64 gal (242 L) | 120 PSI maximum | 120 VAC, 60 Hz, 1Φ, 25 A | Well-ventilated Indoor or outdoor space | 16.5 A | 16,500–24,000 cfm 6,500 sq ft | 60 dBA | 0 to 104 °F (-18 to 40 °C) |

Construction

| Housing | Motor | Controls | Power Supply | Water Supply | Cooling Media | Maintenance |
|--|--|---|--|--|---|---|
| UV-resistant roto-molded polyethylene housing Four locking swivel casters | Variable speed, high-efficiency, totally enclosed 1.5 hp (1.1 kW) | Remote control Onboard control panel Occupancy sensor | Power cord plugs into standard electrical outlet Cord wrap for easy storage | Accepts standard garden hose or portable supply tank Water level regulated by float valve Low-water shutoff for pump longevity | Made from 8 in. (203 mm) thick cross-corrugated formulated cellulose Treated with thermosetting resin for strength and prevention of algae | Accessible reservoir cap for convenient water treatment Drain plug and flush valve for water removal |



Control Options



Remote Control



Onboard Control Panel

Onboard Control Indicators



Power Indicator



Low Water Indicator



Manual Fan Control



Occupancy Sensor



Manual Pump Control



Timer (15 Minutes)

¹ Not suitable for salt air environments.

² Maximum amperage includes both the fan and pump ratings.

³ Fans are sound tested in a laboratory environment. Actual results in field conditions may vary due to sound reflecting surfaces and environmental conditions.

Lead times may vary. See full warranty for coverage information.



USA
BIGASSFANS.COM
877-244-3267

CANADA
BIGASSFANS.COM
844-924-4277

AUSTRALIA
BIGASSFANS.COM/AU
1300 244 277

SINGAPORE
BIGASSFANS.COM/SG
65 6709 8500

MALAYSIA
BIGASSFANS.COM/SG
603 5565 0888